

**BEEM<sup>®</sup> by HEATSAIL**

# TECHNICAL INFORMATION



**RUSTPROOF &  
WEATHERPROOF**



**LOW ENERGY USAGE  
ZERO CO2 EMISSION**



**MINIMUM OF  
MAINTENANCE**

## BEEM<sup>®</sup> by HEATSAIL

### FEATURES



IP  
43

CE



MINIMUM OF  
MAINTENANCE

By using highly-efficient and durable ceramic heating elements and the best materials, the BEEM is virtually maintenance free.



RUSTPROOF &  
WEATHERPROOF

The BEEM is made with high quality aluminium and stainless steel, making it suitable for outdoor use.



UNIQUE  
VERSATILITY

The BEEM is available in four different sizes and with several options making it suitable for almost every location.



LOW ENERGY USAGE  
ZERO CO2 EMISSION

With an energy consumption of only 3.22 kW/h, the BEEM uses less energy than similar products while still delivering optimal heating.



#### Headquarters

Prins Boudewijnlaan 7 Unit A 08  
2550 Kontich  
Belgium  
+ 32 3 502 99 88

#### North American office

10440 N Central Expressway  
Suite 800, Dallas, Texas 75231  
United States  
+ 1 (214) 808 5091

**W:** [www.heatsail.com](http://www.heatsail.com)

**E:** [sales@heatsail.com](mailto:sales@heatsail.com)

## BEEM® by HEATSAIL

### DIMENSIONS

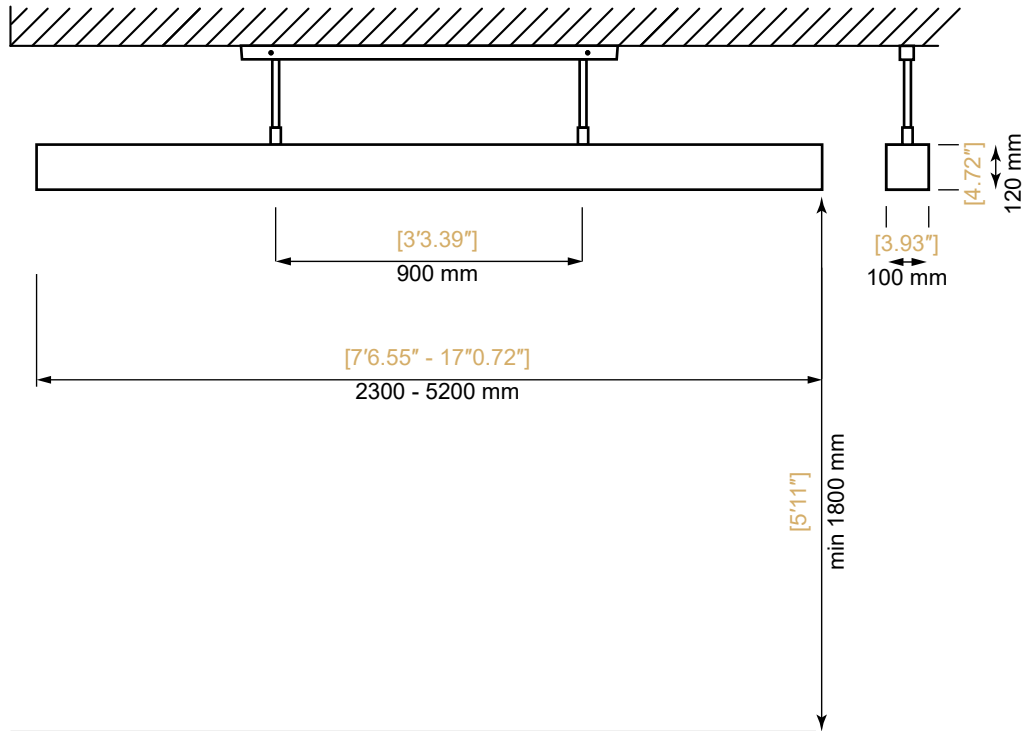

### SPECIFICATIONS

Model	BEEM 230	BEEM 290	BEEM 390	BEEM 520
Heat output (W)	3000 W	3000 W	4000 W	4000 W
Light Output (W)	max 240 W	max 240 W	max 320 W	max 320 W
Electrical connection	110-120/220-240VAC - 50/60Hz 16 A		110-120/220-240VAC - 50/60Hz 16 A	
Approximate area heated (m <sup>2</sup> )	5 m <sup>2</sup> - [54 sq ft]	6 m <sup>2</sup> - [64 sq ft]	8 m <sup>2</sup> - [86 sq ft]	11 m <sup>2</sup> - [118 sq ft]
Dimensions (WxDxH)	2300 x 120 x 100 mm - [7'6.5" x 4.75" x 4"]	2900 x 120 x 100 mm - [9'6" x 4.75" x 4"]	3900 x 120 x 100 mm - [12'9.5" x 4.75" x 4"]	5200 x 120 x 100 mm - [17'1" x 4.75" x 4"]
Mounting height requirement to ground	min 1800 mm; max 2150 mm - [min 5'11"; max 7'1"]			
Ceiling height	min 2120 mm; max 3770 mm - [min 6'11.5"; max 12'5"]			
Weight	+/- 22 kg - [48.5 lbs]	+/- 26 kg - [57.3 lbs]	+/- 35 kg - [77.2 lbs]	+/- 44 kg - [97 lbs]
Approvals	UL 60335-1, CAN/CSA-C22.2 No. 60335-1:16, CAN/CSA-E60335-2-30:13, IEC 60335-2-30, CE			



**Headquarters**  
 Prins Boudewijnlaan 7 Unit A 08  
 2550 Kontich  
 Belgium  
 + 32 3 502 99 88

**North American office**  
 10440 N Central Expressway  
 Suite 800, Dallas, Texas 75231  
 United States  
 + 1 (214) 808 5091

**W:** [www.heatsail.com](http://www.heatsail.com)  
**E:** [sales@heatsail.com](mailto:sales@heatsail.com)

## BEEM<sup>®</sup> by HEATSAIL

### ELECTRICAL SAFETY REQUIREMENTS

The use of the BEEM requires an electrical installation with reliable safety grounding.

The installation's electrical safety can only be guaranteed if the device has been correctly connected to an grounding system built in accordance with the safety instructions. A preliminary inspection is absolutely essential. In the event of any uncertainty, a careful inspection must be made by a qualified and authorized technician. Heatsail will not be held responsible for injury and/or damage resulting from an ungrounded installation.

**The installation of the BEEM's electrical components requires a split phase three wire electrical system of 110-120/220-240V-50/60 Hz (16-20 Amp fuse and appropriate RCD); the connection must be properly implemented in accordance with the applicable IEC-CEI standards. Please note: statutory and other regulation may apply locally.**

This product must be installed by a Qualified Electrician and the power supply connection should be in accordance with the requirements of NFPA 70 and OSHA Regulations 29 CFR 1910.304(b)(2).

The electrical power supply will need to be interrupted using lock-out/tag-out procedures before connecting and/or other work on the electrical components can be carried out. Everyone must satisfy themselves that the power cannot be switched on again accidentally. Electrical adapters, power strips and/or extension cords may not be used for the BEEM's electrical supply. A switch must be installed between the BEEM and the fuse box at all times.

Non-compliance with these instructions may compromise the safety of the device. Heatsail will not be held liable for any damage resulting from this.

NOTE: The BEEM will be delivered with a power supply cord bold wall plug.

### DETAILS CEILING MOUNT

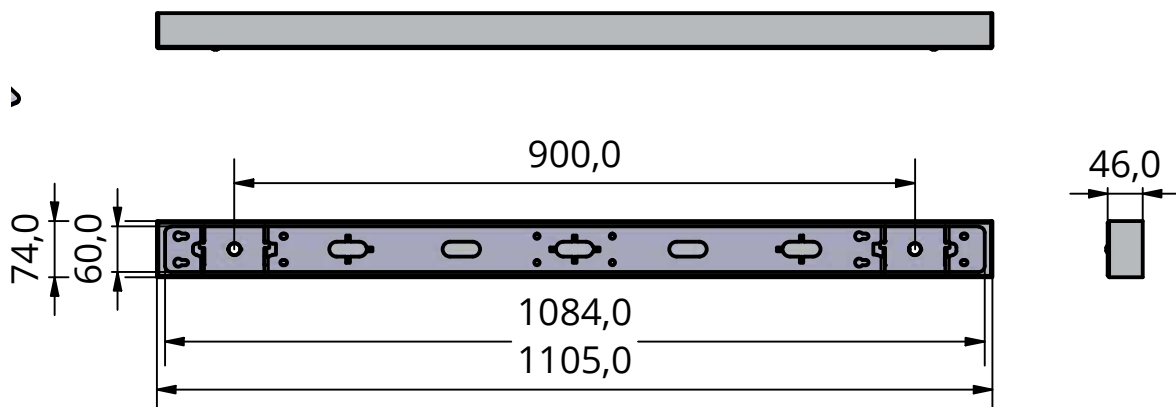

#### Headquarters

Prins Boudewijnlaan 7 Unit A 08  
2550 Kontich  
Belgium  
+ 32 3 502 99 88

#### North American office

10440 N Central Expressway  
Suite 800, Dallas, Texas 75231  
United States  
+ 1 (214) 808 5091

W: [www.heatsail.com](http://www.heatsail.com)

E: [sales@heatsail.com](mailto:sales@heatsail.com)

## BEEM<sup>®</sup> by HEATSAIL

### MOUNTING METHODS: BRACKETS AND STEMS

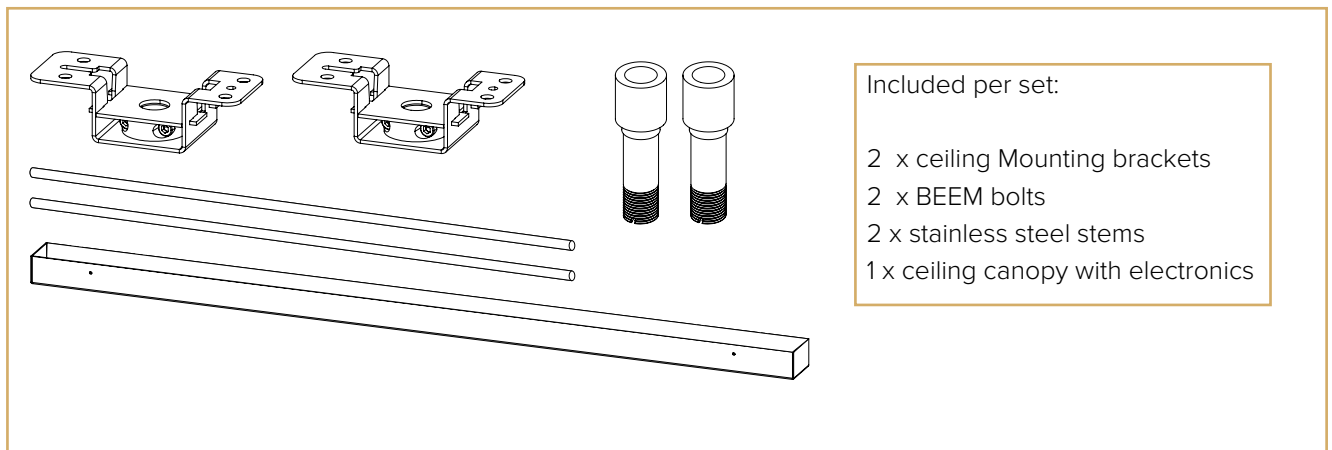
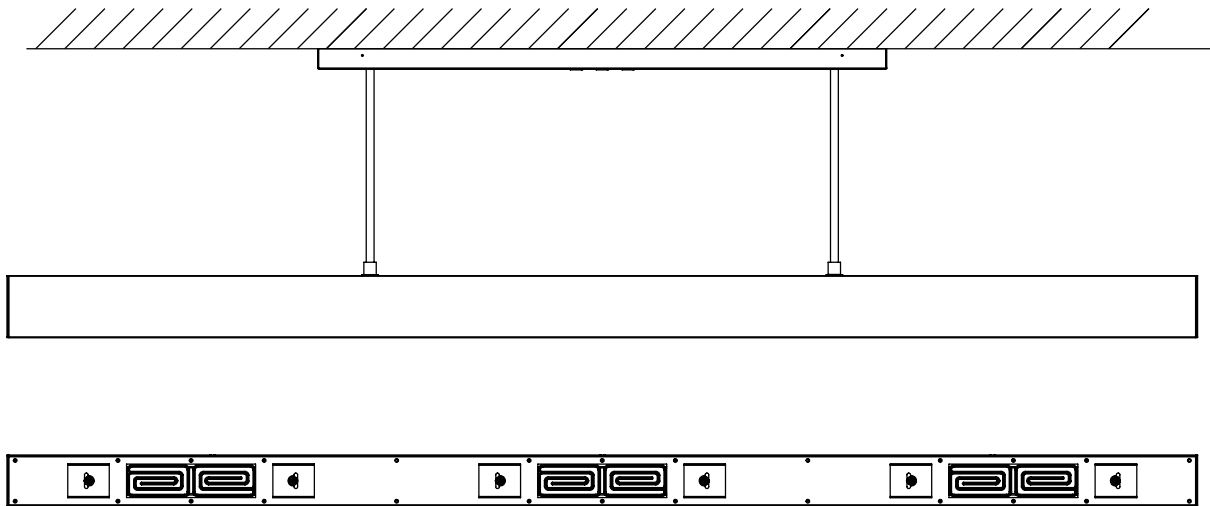

- ✓ Use: Indoor and outdoor (sheltered)
- ✓ For horizontal ceilings
- ✓ Fixed position between the stems: 900 mm
- ✓ Maximum length of the stems: 1500 mm (59 inches)

- ⚠ Supplied stems are 1500 mm: the length needs to be cut by the end user
- ⚠ Always use the correct ceiling anchors and screws according to the mounting surface



**Headquarters**  
Prins Boudewijnlaan 7 Unit A 08  
2550 Kontich  
Belgium  
+ 32 3 502 99 88

**North American office**  
10440 N Central Expressway  
Suite 800, Dallas, Texas 75231  
United States  
+ 1 (214) 808 5091

**W:** [www.heatsail.com](http://www.heatsail.com)  
**E:** [sales@heatsail.com](mailto:sales@heatsail.com)

## BEEM<sup>®</sup> by HEATSAIL

### MOUNTING METHODS: SUSPENSION CABLES

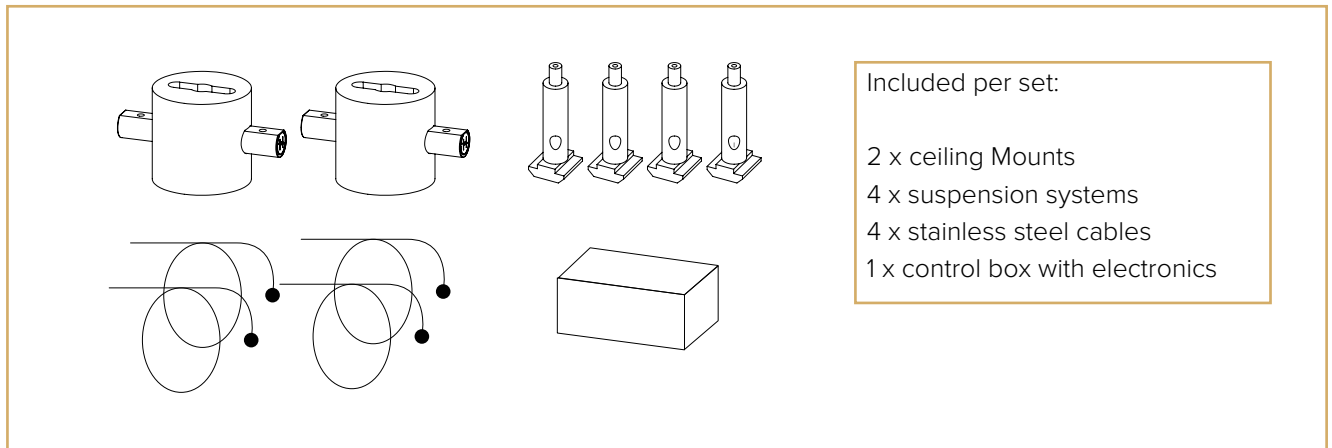
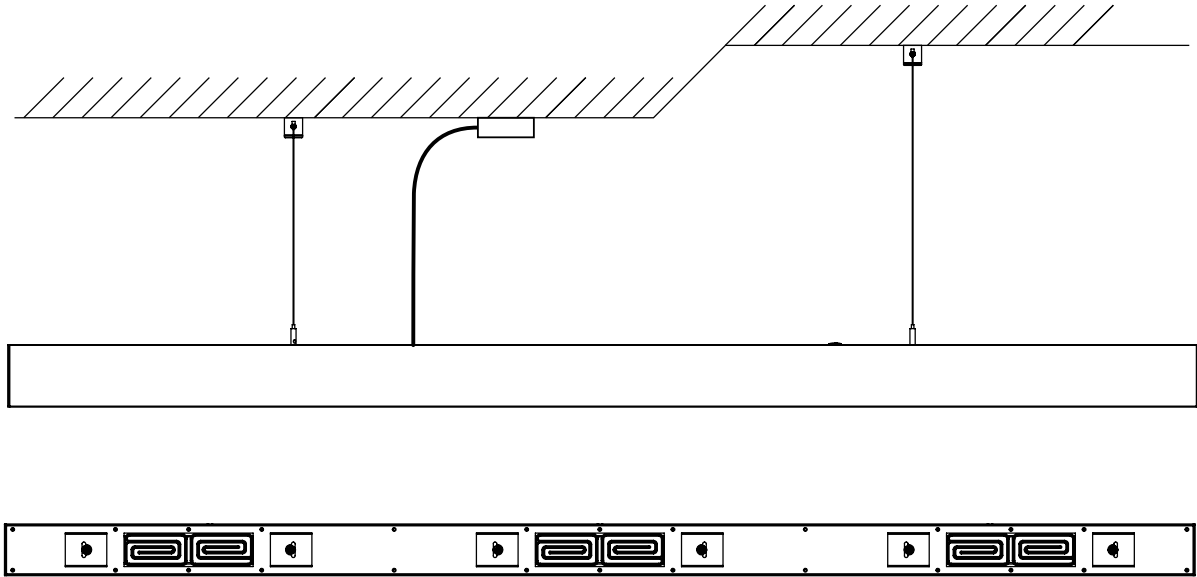

- ✓ Use: Indoor application or winter terrace only
- ✓ For slanted and horizontal ceilings
- ✓ Position between mounts is variable
- ✓ Maximum length of the steel cables: 4000 mm  
(157 inches)
- ! Only to be used in a wind-free environment
- ! Always use the correct ceiling anchors and screws according to the mounting surface



**Headquarters**  
Prins Boudewijnlaan 7 Unit A 08  
2550 Kontich  
Belgium  
+ 32 3 502 99 88

**North American office**  
10440 N Central Expressway  
Suite 800, Dallas, Texas 75231  
United States  
+ 1 (214) 808 5091

**W:** [www.heatsail.com](http://www.heatsail.com)  
**E:** [sales@heatsail.com](mailto:sales@heatsail.com)

## BEEM<sup>®</sup> by HEATSAIL

### ELECTRICAL OVERVIEW

The BEEM consists out of an aluminium enclosure with three to four modules with rectangular heating elements and halogen lamps. Each module has two heating elements of 500 W at 220-240 VAC and two G9 halogen lamps of max 40W at 110-120 VAC.

Because of the high heat a LED lamp is not possible, LED cannot withstand high temperatures that the BEEM outputs.

There are three electrical circuits in the BEEM. These circuits have a total of 14-16 Amps at 110-120/220-240 VAC

- |                                    |  |
|------------------------------------|--|
| <p><b>B230</b><br/><b>B290</b></p> | <ul style="list-style-type: none"> <li>• Circuit 1: Heating circuit 1 consists of three rectangular heater elements and has a total heat output of 1500 W at 220-240 VAC.</li> <li>• Circuit 2: Heating circuit 2 consists of three rectangular heater elements and has a total heat output of 1500 W at 220-240 VAC.</li> <li>• Circuit 3: Lighting circuit consists of six G9 bulbs of max 40 W at 110-120 VAC.</li> </ul> |
| <p><b>B390</b><br/><b>B520</b></p> | <ul style="list-style-type: none"> <li>• Circuit 1: Heating circuit 1 consists of four rectangular heater elements and has a total heat output of 2000 W at 220-240 VAC.</li> <li>• Circuit 2: Heating circuit 2 consists of four rectangular heater elements and has a total heat output of 2000 W at 220-240 VAC.</li> <li>• Circuit 3: Lighting circuit consists of eight G9 bulbs of max 40 W at 110-120 VAC.</li> </ul> |

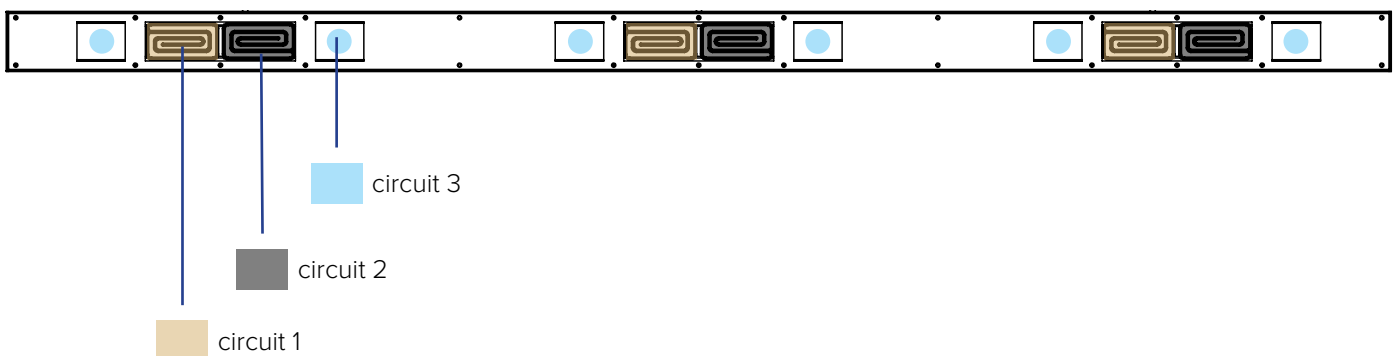

## BEEM<sup>®</sup> by HEATSAIL

### ELECTRICAL CONNECTION

The BEEM has to be wired via wall switches: The incoming power is divided over the three circuits through three wall switches installed by a qualified electrician. The output lines of the wall switches will consist of six lines in a size not less than 1.5 mm<sup>2</sup> / 16 AWG according to the following drawing:

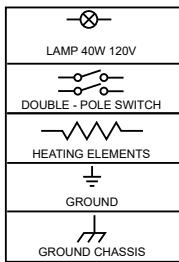

#### CONNECTION LIGHT 110-120V AC

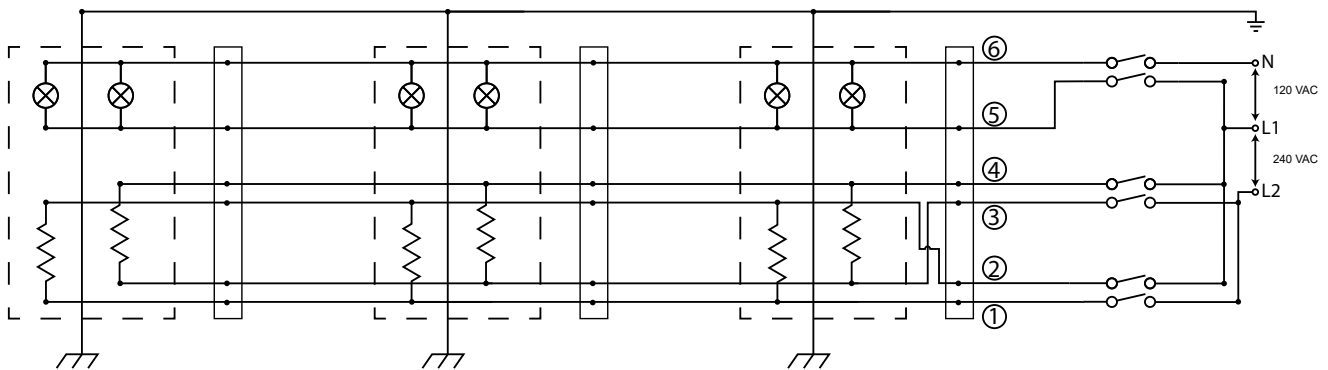

#### CONNECTION LIGHT 220-240V AC

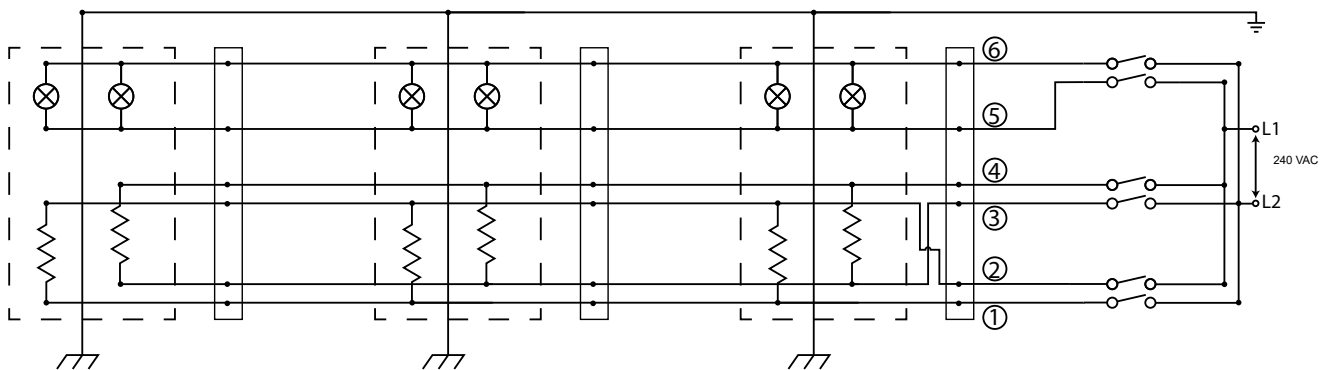

To connect the BEEM to the main power, a three pole connection is required consisting of two hot wires (with an output of 110-120/220-240V AC-60 Hz) a Neutral wire and one grounding wire in a size not less than 1.5 mm<sup>2</sup> / 16 AWG. For safety reasons 2.5 mm<sup>2</sup> / 14 AWG is recommended.



**Headquarters**  
 Prins Boudewijnlaan 7 Unit A 08  
 2550 Kontich  
 Belgium  
 + 32 3 502 99 88

**North American office**  
 10440 N Central Expressway  
 Suite 800, Dallas, Texas 75231  
 United States  
 + 1 (214) 808 5091

**W:** [www.heatsail.com](http://www.heatsail.com)  
**E:** [sales@heatsail.com](mailto:sales@heatsail.com)



## BEEM<sup>®</sup> by HEATSAIL

### MISTING: SUMMARY

An addition to the standard BEEM is an integrated misting system consisting of a high pressure stainless tubing system and high quality nozzles with an orifice between 0.10 and 0.20 mm and 6.35 mm PA12 tubing, to cool down the surrounding temperature up to 10 °C, depending on climate and humidity.

The mist is produced by means of a pump that pressurizes water up to 70 bar forcing the water out of the nozzles at high pressure, cooling the surrounding air.

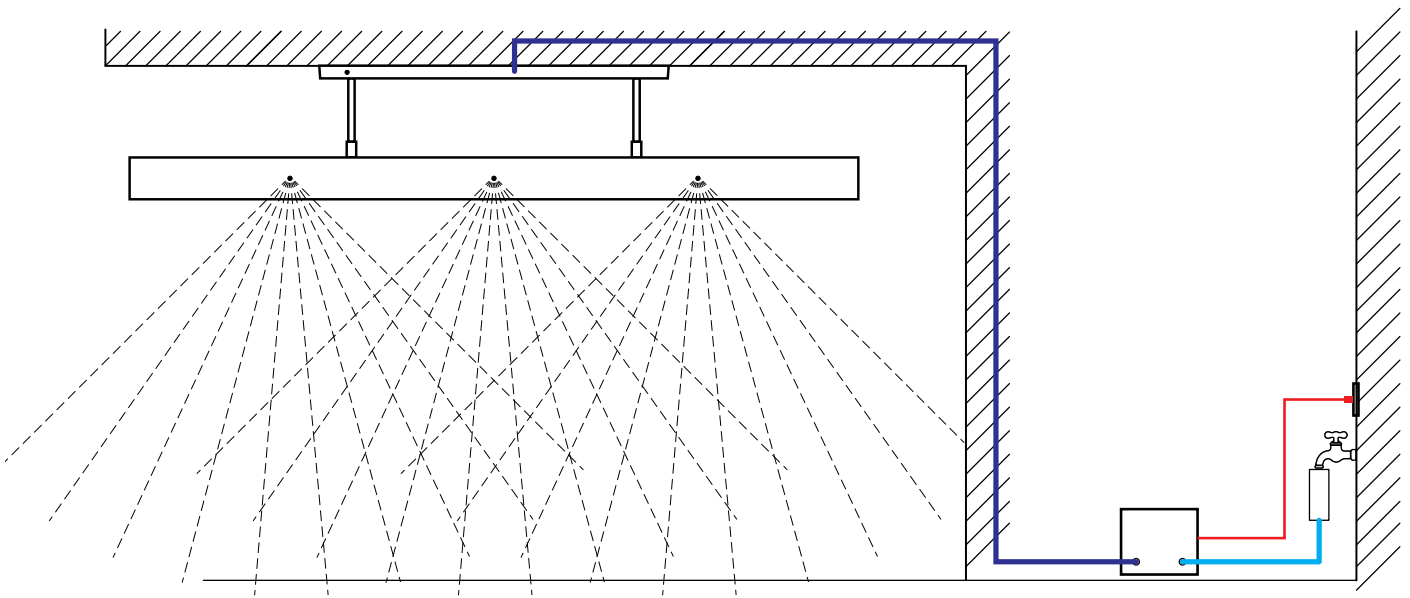

### MISTING: CAPACITY

The misting version of the B230 and B290 will hold 2 x 3 misting nozzles and will have a cooling capacity of approx 12 m<sup>2</sup>

The misting version of the B390 and B520 will hold 2 x 4 misting nozzles and will have a cooling capacity of approx 16 m<sup>2</sup>

Plugs are available to close nozzles if necessary.

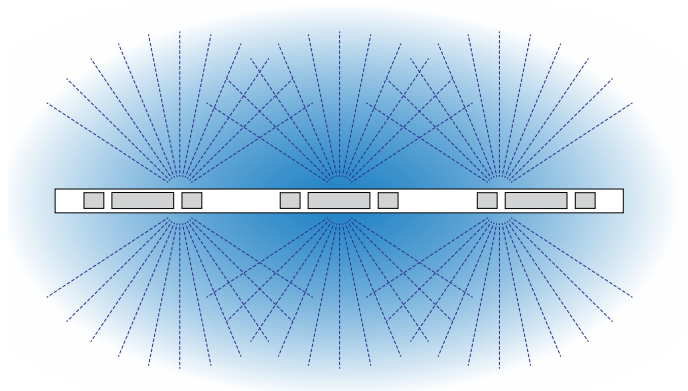

**Headquarters**  
Prins Boudewijnlaan 7 Unit A 08  
2550 Kontich  
Belgium  
+ 32 3 502 99 88

**North American office**  
10440 N Central Expressway  
Suite 800, Dallas, Texas 75231  
United States  
+ 1 (214) 808 5091

**W:** [www.heatsail.com](http://www.heatsail.com)  
**E:** [sales@heatsail.com](mailto:sales@heatsail.com)

## BEEM<sup>®</sup> by HEATSAIL

### MISTING: CONSTRUCTION

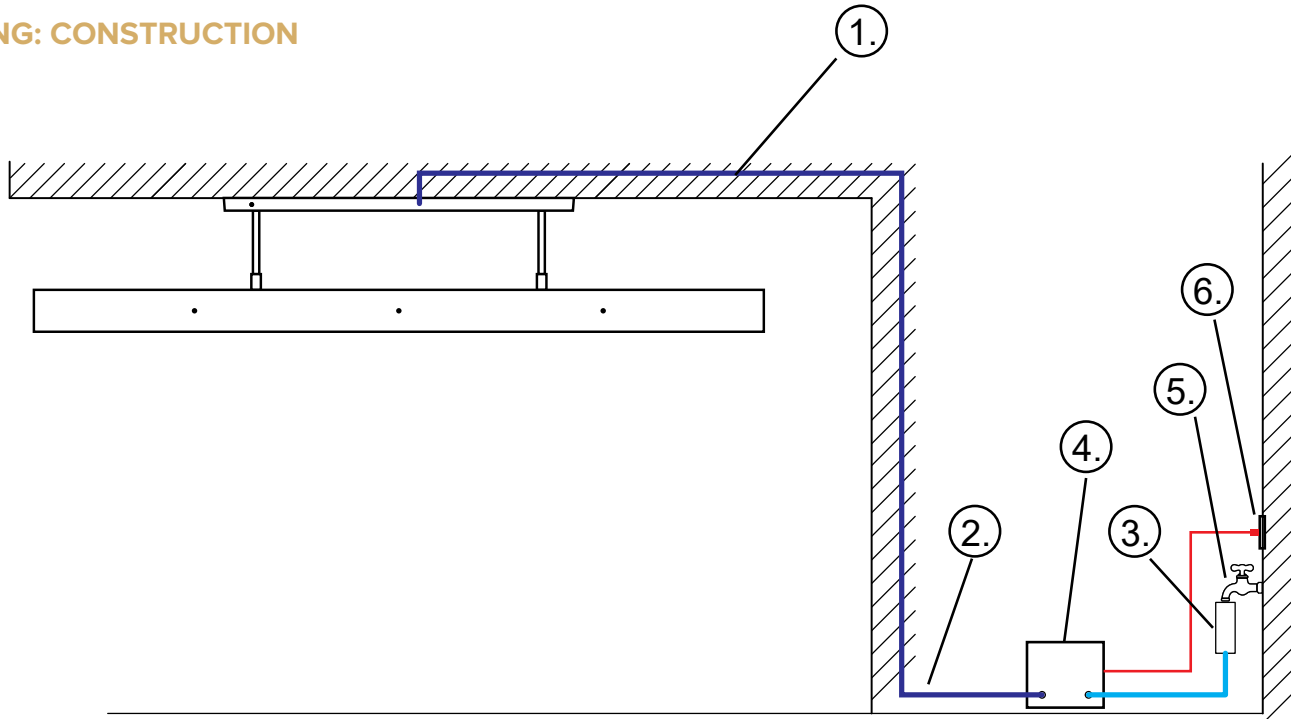

1.

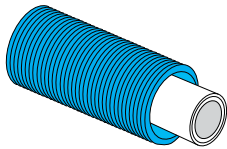

[Art.170.10.010] Tube in tube, to be installed by a plumber at construction\*.

2.

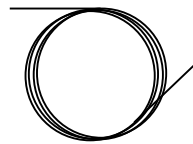

[Art.170.10.001] PA12 Tube (6.35 mm dia ). 5m is supplied with the product. Longer tubing is available\*.

3.

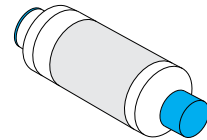

[Art.170.10.020] A Calcium filter should be placed in between the water supply and the misting pump\*.

4.

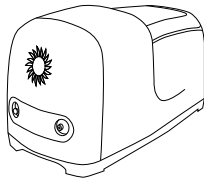

[Art.170.10.030] A misting pump is required to be installed providing pressure up to 70 bar\*.

5.

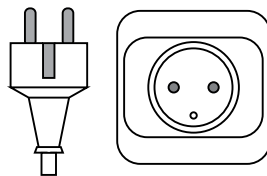

A power supply is required to power the misting pump.

6.

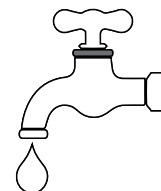

A water supply is required at the inlet of the misting pump.

\*sold separately.



**Headquarters**  
Prins Boudewijnlaan 7 Unit A 08  
2550 Kontich  
Belgium  
+ 32 3 502 99 88

**North American office**  
10440 N Central Expressway  
Suite 800, Dallas, Texas 75231  
United States  
+ 1 (214) 808 5091

**W:** [www.heatsail.com](http://www.heatsail.com)  
**E:** [sales@heatsail.com](mailto:sales@heatsail.com)

## BEEM<sup>®</sup> by HEATSAIL

### MISTING: CONSTRUCTION

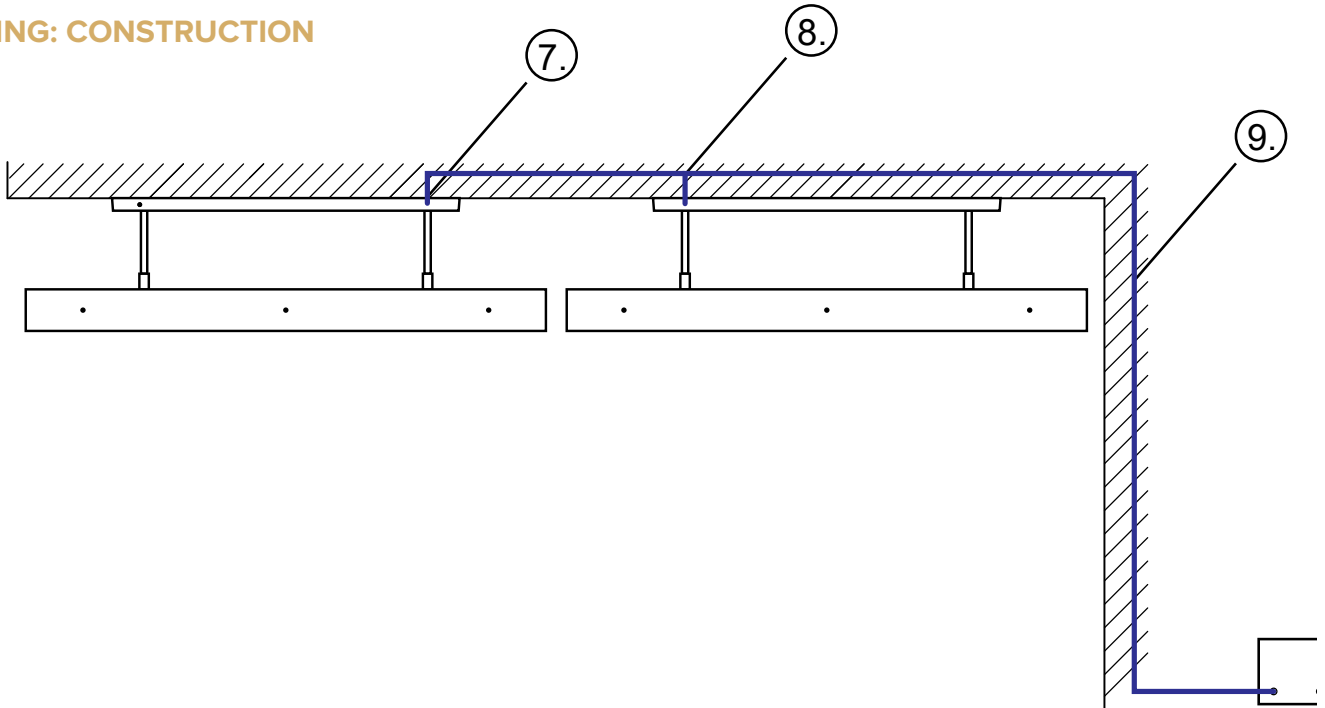

7.

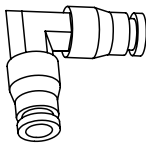

[Art.170.10.002] L-piece quick connector for 6.35 mm tubing. 2 pieces included.

8.

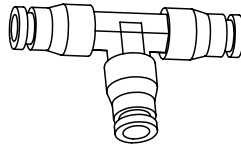

[Art.170.10.003] T-piece quick connector for 6.35 mm tubing\*.

9.



[Art.170.10.004] Pipe extender for 6.35 mm tubing\*.

Pressure	70 bar/ 1000 psi
Motor	110VAC - 240 VAC
Power	180 W
Noise with pressure	56 dB
Maintainance time	800-1000h
Operation	app / buttons, switch

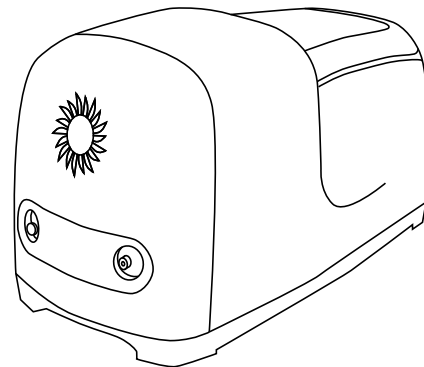

\*sold seperately.



**Headquarters**  
 Prins Boudewijnlaan 7 Unit A 08  
 2550 Kontich  
 Belgium  
 + 32 3 502 99 88

**North American office**  
 10440 N Central Expressway  
 Suite 800, Dallas, Texas 75231  
 United States  
 + 1 (214) 808 5091

**W:** [www.heatsail.com](http://www.heatsail.com)  
**E:** [sales@heatsail.com](mailto:sales@heatsail.com)