

**DOME<sup>®</sup> PT by HEATSAIL**

# TECHNICAL INFORMATION



**RUSTPROOF &  
WEATHERPROOF**



**LOW ENERGY USAGE  
ZERO CO2 EMISSION**



**MINIMUM OF  
MAINTENANCE**

## DOME® PT by HEATSAIL

### FEATURES



**MINIMUM OF  
MAINTENANCE**

By using high efficient and durable ceramic heating elements and the best materials, the DOME PT is virtually maintenance free.



**RUSTPROOF &  
WEATHERPROOF**

The DOME PT is made out of high quality material such as Aluminium and Stainless steel, making it suitable for outdoor use.



**PATENTED  
DESIGN**

The unique patented design makes the DOME PT an absolute eyecatcher, exuding luxury, elegance and exclusivity.



**LOW ENERGY USAGE  
ZERO CO2 EMISSION**

With an energy consumption of only 3.22 kW/h, the DOME PT uses less energy than similar products delivering optimal heating.



**Headquarters**

Prins Boudewijnlaan 7 Unit A 08  
2550 Kontich  
Belgium  
+ 32 3 502 99 88

**North American office**

10440 N Central Expressway  
Suite 800, Dallas, Texas 75231  
United States  
+ 1 (214) 808 5091

**W:** [www.heatsail.com/usa](http://www.heatsail.com/usa)

**E:** [ucm@heatsail.com](mailto:ucm@heatsail.com)

## DOME® PT by HEATSAIL

### DIMENSIONS

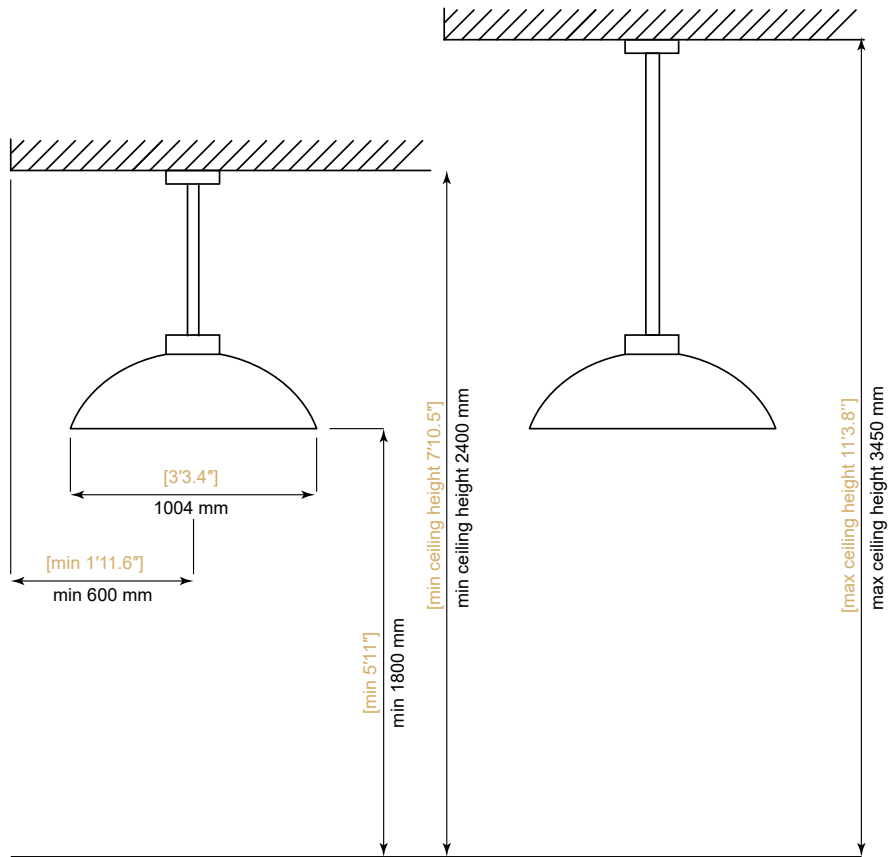

### SPECIFICATIONS

Model	DOME PT
Heat output (W)	3100 W
Light Output (W)	120 W
Electrical connection	Optional 208V AC - 60 Hz 20 A
Dimensions (W)	1004 mm - [3'3.4"]
Mounting height requirement to ground	min 1800 mm; max 1950 mm - [min 5'11"; max 6'4.8"]
Ceiling height	min 2400 mm; max 3770 mm - [min. 7'10.5"; max. 12'4.4"]
Weight	approx. 24 kg - [53 lbs]
Approvals	UL 60335-1, CAN/CSA-C22.2 No. 60335-1:16, CAN/CSA-E60335-2-30:13, IEC 60335-2-30, CE



**Headquarters**  
 Prins Boudewijnlaan 7 Unit A 08  
 2550 Kontich  
 Belgium  
 + 32 3 502 99 88

**North American office**  
 10440 N Central Expressway  
 Suite 800, Dallas, Texas 75231  
 United States  
 + 1 (214) 808 5091

**W:** [www.heatsail.com/usa](http://www.heatsail.com/usa)  
**E:** [ucm@heatsail.com](mailto:ucm@heatsail.com)

## DOME® PT by HEATSAIL

### ELECTRICAL SAFETY REQUIREMENTS

The use of the DOME PT requires an electrical installation with reliable safety grounding.

The installation's electrical safety can only be guaranteed if the device has been correctly connected to a grounding system built in accordance with the safety instructions. A preliminary inspection is absolutely essential. In the event of any uncertainty, a careful inspection must be done by a qualified and authorised technician. Heatsail will not be held responsible for injury and/or damage resulting from an ungrounded installation.

**The installation of the DOME's PT electrical components requires a main connection of 208V AC-60 Hz (20 amp fuse appropriate RCD): the connection must be properly implemented in accordance with the applicable IEC-CEI standards. This product must be installed by a Qualified Electrician and the power supply connection should be in accordance with the requirements of NFPA 70 and OSHA Regulations 29 CFR 1910.304(b)(2).**

**Please note: statutory and other regulation may apply locally.**

Before carrying out any maintenance or other work, the power supply must be disconnected by a licensed electrician. Use Lock-out/Tagout procedures to ensure that the power can't be switched on again accidentally. Adapters, power strips and extension cords may not be used for the DOME's PT electrical supply. A switch must be installed between the DOME PT and the fuse box at all times.

Noncompliance with these instructions may compromise the safety of the device. Heatsail will not be held liable for any damage resulting from these issues.

**Please note:** The DOME PT will not be delivered with a supply cord.

### CEILING ROSE OVERVIEW

The DOME PT is mounted to the ceiling with a stainless steel suspension bracket. This bracket should be hung by using the correct plugs and screws according to the mounting surface. The diameter of the ceiling rose is 7.87 inch (200mm).

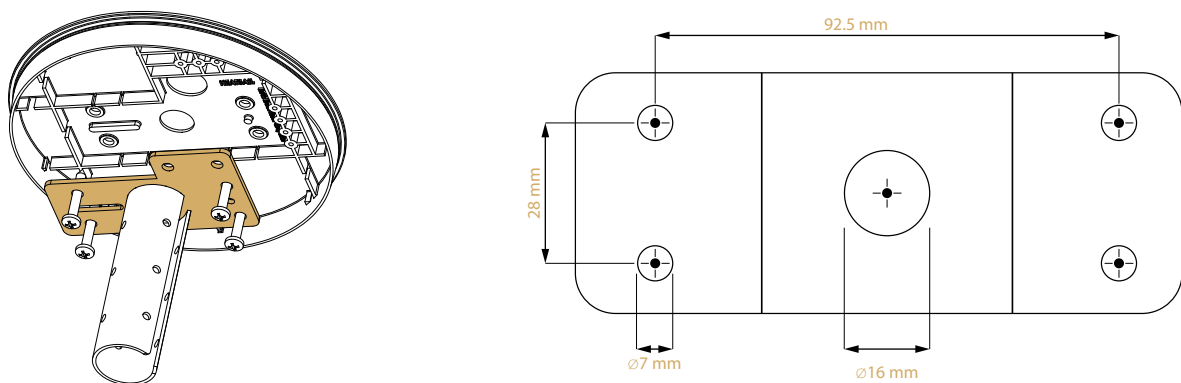

**Headquarters**  
Prins Boudewijnlaan 7 Unit A 08  
2550 Kontich  
Belgium  
+ 32 3 502 99 88

**North American office**  
10440 N Central Expressway  
Suite 800, Dallas, Texas 75231  
United States  
+ 1 (214) 808 5091

**W:** [www.heatsail.com/usa](http://www.heatsail.com/usa)  
**E:** [ucm@heatsail.com](mailto:ucm@heatsail.com)

## DOME® PT by HEATSAIL

### ELECTRICAL OVERVIEW

The DOME PT consists of a central heating element with a light, the hood of the 'DOME PT' which serves as protection and reflection of the far infrared rays. The central element is called 'heattube'. On the lower part you will find a 'heater block' with 5 rectangular and 1 round heater element. Above the heater block there is a halogen light, separated from the heater elements. The light consists of an R7S 78 mm halogen bulb, at 208V-240V AC, behind a heat resistant glass. The glass can be lifted upwards to change the halogen bulb. A LED lamp couldn't be integrated as LED lights can not withstand these high temperatures.

There are three electrical circuits within the heattube. These circuits have a total of 20 amps at 208V AC.

- Circuit 1: consists of three rectangular heating elements and has a total heat output of 1500 W at 208V AC
- Circuit 2: consists of two rectangular heating elements and the lower round heating element and has a heat output of 1600 W at 208V AC
- Circuit 3: consists of a R7S bulb of 120 W at 208V AC

### INSTALLATION OPTIONS

#### • Controlled by our remote control

The incoming power is divided over the three circuits through three electronic receivers, mounted in the ceiling rose. The electronic receivers are operated by a remote control. Always ensure that the power between the main breaker and the DOME PT can be switched off by other means than the remote control, by use of a 2 pole switch.

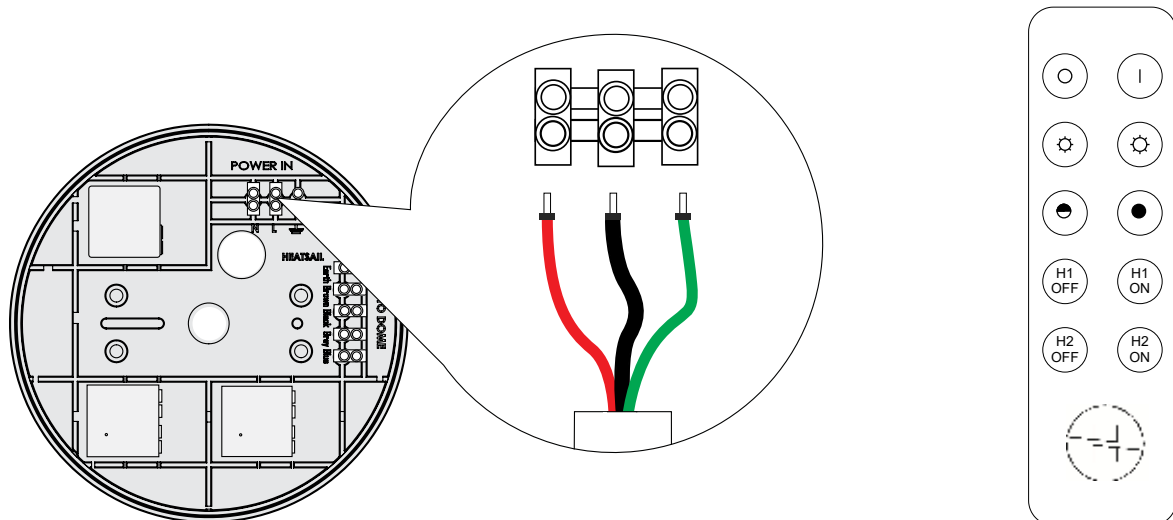

**To connect the DOME to the main power, a single phase connection is required consisting of 2 hot wire and 1 grounding wire in a size not less than 2.5 mm<sup>2</sup> / 14 AWG.**



**Headquarters**  
Prins Boudewijnlaan 7 Unit A 08  
2550 Kontich  
Belgium  
+ 32 3 502 99 88

**North American office**  
10440 N Central Expressway  
Suite 800, Dallas, Texas 75231  
United States  
+ 1 (214) 808 5091

**W:** [www.heatsail.com/usa](http://www.heatsail.com/usa)  
**E:** [ucm@heatsail.com](mailto:ucm@heatsail.com)

## DOME® PT by HEATSAIL

- **Controlled by wall switch or an integrated system**

The incoming power is divided over the 3 circuits through 3 wall switches installed by a qualified electrician. The output lines of the wall switches will consist of 5 lines in a size not less than 2.5 mm<sup>2</sup> / 14 AWG according to the following indicative wiring diagram:

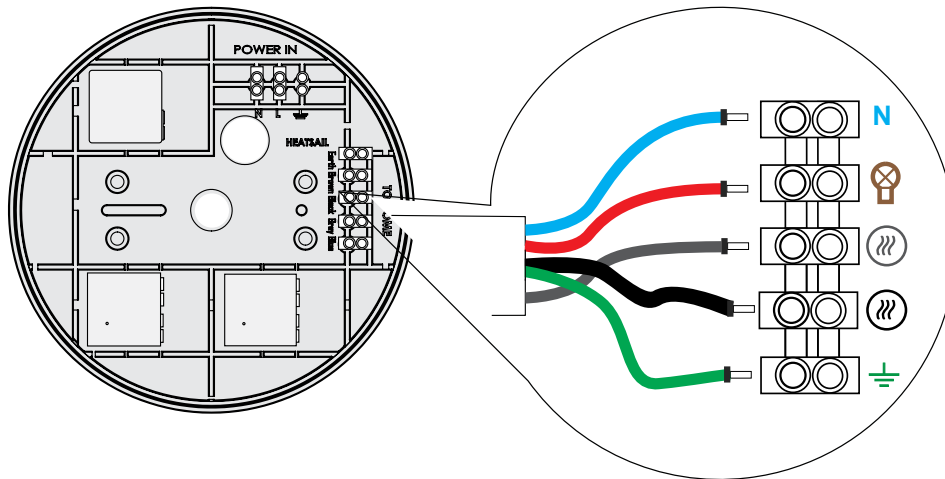
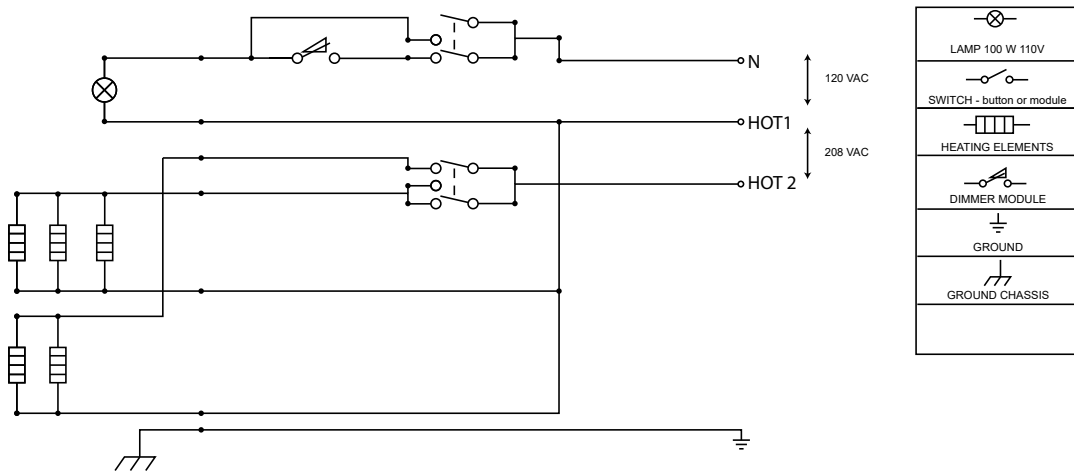

**To connect the DOME to the main power, a three phase connection is required consisting of 3 hot wire and a neutral (with an output of 120/208V AC - 60 Hz) and 1 grounding wire in a size not less than 2.5 mm<sup>2</sup> / 14 AWG.**



**Headquarters**  
 Prins Boudewijnlaan 7 Unit A 08  
 2550 Kontich  
 Belgium  
 + 32 3 502 99 88

**North American office**  
 10440 N Central Expressway  
 Suite 800, Dallas, Texas 75231  
 United States  
 + 1 (214) 808 5091

**W:** [www.heatsail.com/usa](http://www.heatsail.com/usa)  
**E:** [ucm@heatsail.com](mailto:ucm@heatsail.com)

## DOME® PT by HEATSAIL

### AVAILABLE LENGTHS: FOR REGULAR TABLES

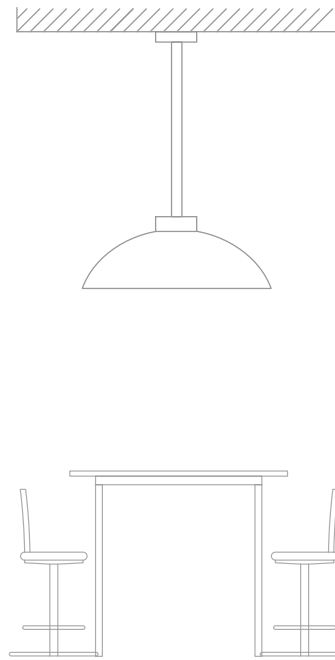
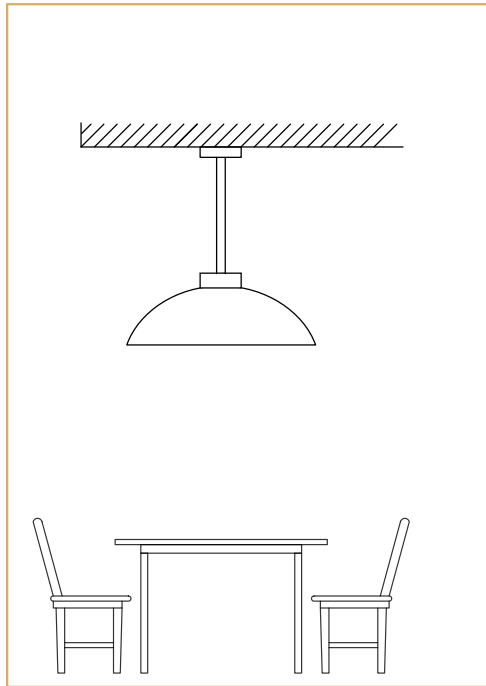

LENGTH STEM		CEILING HEIGHT		EXTENSION PIECE
20	7,9"	240 - 247 cm	7'10,5" - 8'1,2"	
		248 - 254 cm	8'1,6" - 8'4,0"	One
		255 - 269 cm	8'4,4" - 8'9,9"	Two
50	19,7"	270 - 277 cm	8'10,3" - 9'1,1"	
		278 - 284 cm	9'1,4" - 9'3,8"	One
		285 - 299 cm	9'4,2" - 9'9,7"	Two
80	31,5"	300 - 307 cm	9'10,1" - 10'0,9"	
		308 - 314 cm	10'1,3" - 10'3,6"	One
		315 - 329 cm	10'4,0" - 10'9,5"	Two
110	43,3"	330 - 337 cm	10'9,9" - 11'0,7"	
		338 - 344 cm	11'1,1" - 11'3,4"	One
		345 - 352 cm	11'3,8" - 11'6,6"	Two

Calculation: vertical clearance 5'10,9" (180cm) + ceiling rose 0'0,8" (2cm) + hood 1'3,0" (38cm) + stem size



**Headquarters**  
 Prins Boudewijnlaan 7 Unit A 08  
 2550 Kontich  
 Belgium  
 + 32 3 502 99 88

**North American office**  
 10440 N Central Expressway  
 Suite 800, Dallas, Texas 75231  
 United States  
 + 1 (214) 808 5091

**W:** [www.heatsail.com/usa](http://www.heatsail.com/usa)  
**E:** [ucm@heatsail.com](mailto:ucm@heatsail.com)

## DOME® PT by HEATSAIL

### AVAILABLE LENGTHS: FOR REGULAR TABLES

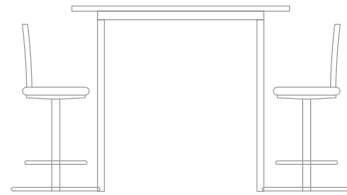
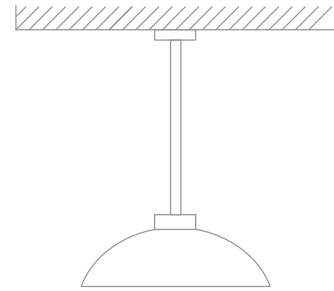
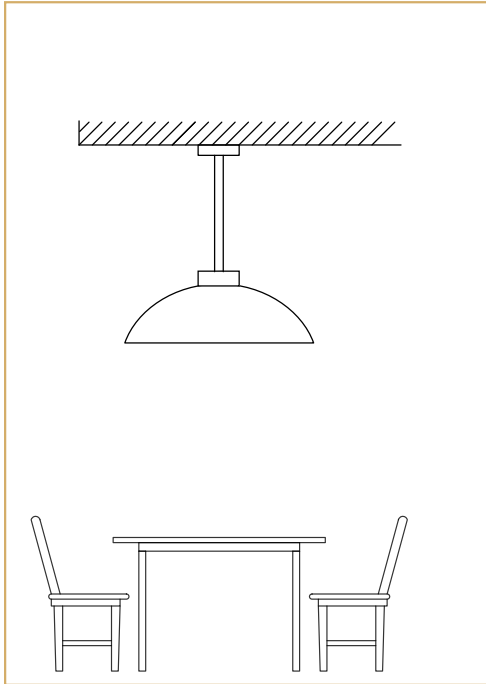

LENGTH STEM		CEILING HEIGHT		EXTENSION PIECE
20	7,9"	240 - 247 cm	7'10,5" - 8'1,2"	
		248 - 254 cm	8'1,6" - 8'4,0"	One
		255 - 269 cm	8'4,4" - 8'9,9"	Two
50	19,7"	270 - 277 cm	8'10,3" - 9'1,1"	
		278 - 284 cm	9'1,4" - 9'3,8"	One
		285 - 299 cm	9'4,2" - 9'9,7"	Two
80	31,5"	300 - 307 cm	9'10,1" - 10'0,9"	
		308 - 314 cm	10'1,3" - 10'3,6"	One
		315 - 329 cm	10'4,0" - 10'9,5"	Two
110	43,3"	330 - 337 cm	10'9,9" - 11'0,7"	
		338 - 344 cm	11'1,1" - 11'3,4"	One
		345 - 352 cm	11'3,8" - 11'6,6"	Two

Calculation: vertical clearance 5'10,9" (180cm) + ceiling rose 0'0,8" (2cm) + hood 1'3,0" (38cm) + stem size



**Headquarters**  
 Prins Boudewijnlaan 7 Unit A 08  
 2550 Kontich  
 Belgium  
 + 32 3 502 99 88

**North American office**  
 10440 N Central Expressway  
 Suite 800, Dallas, Texas 75231  
 United States  
 + 1 (214) 808 5091

**W:** [www.heatsail.com/usa](http://www.heatsail.com/usa)  
**E:** [ucm@heatsail.com](mailto:ucm@heatsail.com)



## DOME® PT by HEATSAIL

### AVAILABLE LENGTHS: FOR HIGH TABLES

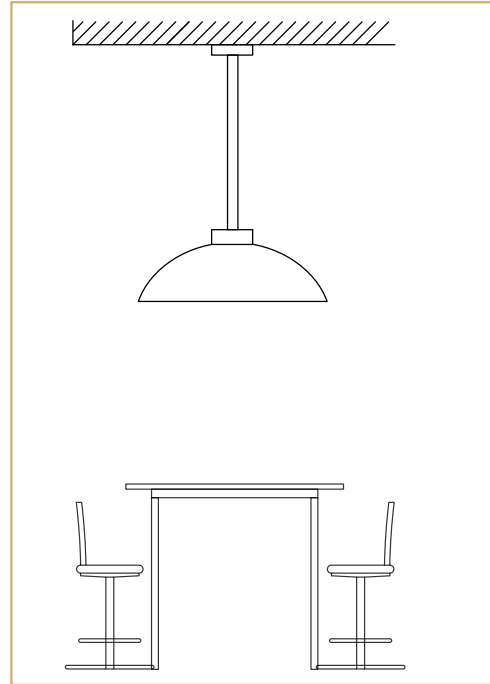
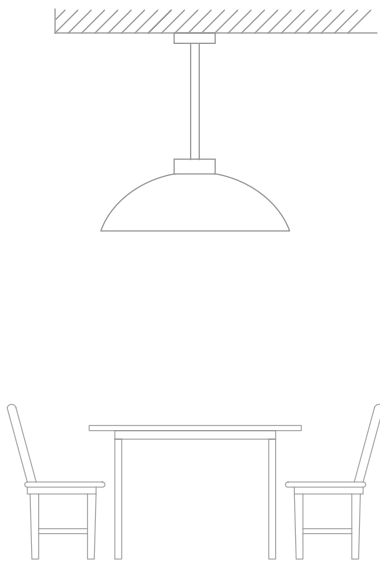

LENGTH STEM		CEILING HEIGHT		EXTENSION PIECE
20	7,9"	255 - 262 cm	8'4,4" - 8'7,1"	
		263 - 269 cm	8'7,5" - 8'9,9"	One
		270 - 284 cm	8'10,3" - 9'3,8"	Two
50	19,7"	285 - 292 cm	8'4,2" - 9'7,0"	
		293 - 299 cm	9'7,4" - 9'9,7"	One
		300 - 314 cm	9'10,1" - 10'3,6"	Two
80	31,5"	315 - 322 cm	10'4,0" - 10'6,8"	
		323 - 329 cm	10'7,2" - 10'9,5"	One
		330 - 344 cm	10'9,9" - 11'3,4"	Two
110	43,3"	345 - 352 cm	11'3,8" - 11'6,6"	
		353 - 359 cm	11'7,0" - 11'9,3"	One
		360 - 367 cm	11'9,7" - 12'0,5"	Two

Calculation: vertical clearance 6'4,8" (195cm) + ceiling rose 0'0,8" (2cm) + hood 1'3,0" (38cm) + stem size



**Headquarters**  
 Prins Boudewijnlaan 7 Unit A 08  
 2550 Kontich  
 Belgium  
 + 32 3 502 99 88

**North American office**  
 10440 N Central Expressway  
 Suite 800, Dallas, Texas 75231  
 United States  
 + 1 (214) 808 5091

**W:** [www.heatsail.com/usa](http://www.heatsail.com/usa)  
**E:** [ucm@heatsail.com](mailto:ucm@heatsail.com)